

SCRUBBER DRYERS.
10 TO 150 LITRES

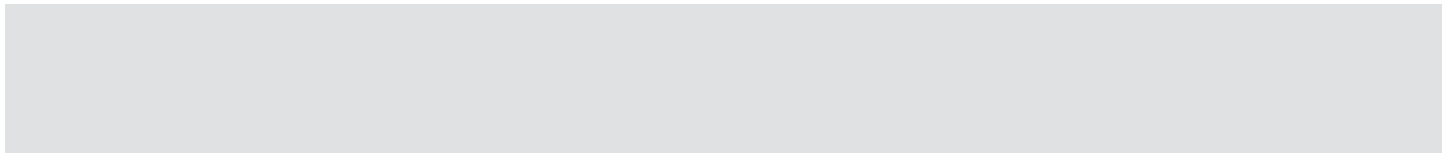

CLEAN QUALITY

SINCE 1926

www.columbus-clean.com







ONE LIKE THE OTHER: KNOW-HOW AND TECHNOLOGY FROM GERMANY.

**10 litres
battery-operated
mains-operated**



Theoretical coverage max.
1400 m²/h
Working width 350 mm
Working time up to 1,5 h

**20 litres
battery-operated**



Theoretical coverage max.
1720 m²/h
Working width 430 mm
Working time up to 2,5 h

**40 litres
mains-operated**



Theoretical coverage max.
1720 to 2200 m²/h
Working width 430 and 550 mm

**40 litres
battery-operated**



Theoretical coverage max.
1720 to 2200 m²/h
Working width 430 and 550 mm
Working time up to 3,5 h

**60 litres
mains-operated**



Theoretical coverage max.
2640 m²/h
Working width 660 mm

**60 litres
battery-operated**



Theoretical coverage max.
2200 to 2640 m²/h
Working width 550 and 660 mm
Working time up to 5 h

**90 Liter
battery-operated**



page 26

Theoretical coverage max.
3360 m²/h
Working width 850 mm
Working time up to 5 h

**70 litres
battery-operated**



page 32

Theoretical coverage max.
4620 m²/h
Working width 660 mm
Working time up to 4 h

**100 litres
battery-operated**



page 36

Theoretical coverage max.
4620 to 5600 m²/h
Working width 660 and 800 mm
Working time up to 8 h

**120 litres
battery-operated**



page 40

Theoretical coverage max.
5950 m²/h
Working width 850 mm
Working time up to 6 h

**150 litres
battery-operated**



page 44

Theoretical coverage max.
6000 to 7500 m²/h
Working width 800 and 1000 mm
Working time up to 10 h

**scrubber dryers
with noBAC® system**



page 50

Antibacterial solution and recovery
tanks

SO SMALL, SO MANOEUVRABLE.

RA 35|B 10

RA 35|K 10



Ⓞ The low cost scrubber dryer ideal for use in small areas and heavily congested spaces.

Ⓞ Thorough cleaning up to the edge: consistently high brush pressure in combination with a swivel-mounted squeegee, which is located directly behind the brush.

Ⓞ Large wheels for excellent manoeuvrability and easy transport.

Ⓞ Guaranteed perfect working height: the ergonomically shaped handlebar can be adjusted to four different heights.

Ⓞ The ultra compact design with a bevelled front provides for good cleaning under furnishings or around obstacles.

Ⓞ Hygienic according to HACCP standards: the removable recovery tank can be cleaned and disinfected easily; the cover gasket replaced in no time. Excess fresh water can be drained completely.

Ⓞ Operating handle can be folded flat across the scrubber dryer for easy transport in small vehicles and storage in tight spaces.

Ⓞ Easy cleanout of recovery tank through outlet valve into floor drain. Or, easy and functional: by simply removing the tank and tipping the dirty water into any sink.

Ⓞ Mains operated version for continuous working time, with powerful suction, lightweight for easy carriage and transport.

Ⓞ EUnited tested and certified.



RA 35|B 10

RA 35|K10

L x W x H	735 x 490 x 650 mm	735 x 490 x 650 mm
Working width	350 mm	350 mm
Suction width	420 mm	420 mm
Theoretical coverage max.	1400 m ² /h	1400 m ² /h
Noise level	66 dB(A)	66 dB(A)
Empty weight	44 kg	39 kg
Operating weight	74 kg (63 Ah 5)	49 kg

BATTERIES/ELECTRICAL DATA

Rated voltage	24 V	230 V
Power max.	440 W	470 W
Number of batteries	1	
Capacity gel	63 Ah 5	
Mains cable		12 m

TANK

Solution tank capacity	10 l	10 l
Recovery tank capacity	11,5 l	11,5 l

SUCTION

Low pressure max.	52 mbar	52 mbar
Air flow max.	14,5 l/s	14,5 l/s

BRUSHES AND PAD HOLDERS

Number	1	1
Speed	180 rpm	190 rpm
Brush pressure	28 kg	28 kg



COMPACT. PROFESSIONAL. 20 LITRES.

RA 43|B 20

- With lots of handy details and long operating intervals, the RA 43|B 20 shows its class in clinics, homes for the elderly, schools, shops, swimming and leisure centres, to name but a few locations – where compactness and manoeuvrability are decisive.
- A uniaxial construction with biaxial comfort: the transportation wheel is lowered by foot pedal. This means the machine can easily be moved to the area where it is to be used, the pressure on the brush is relieved during storage and the brush can dry properly.
- Work close to edges and get underneath objects without difficulty: the brush head protrudes out 5 cm to the side.
- For easy access to batteries and motors, the recovery tank can be removed quickly and without tools.
- Hygiene in accordance with HACCP: the recovery tank can be thoroughly and effortlessly cleaned and disinfected via the large opening.
- DEKRA and EUnited tested and certified.
- Made in Germany.





Self explaining control panel



Quick-Stop as standard

- The working width of 43 cm provides extended fields of applications and greater area coverage in the 20-litre class.
- Quick-Stop as standard: the brush motor and water supply stop automatically when you let go the handle.

- The recovery tank can be easily tilted and then comfortably and precisely emptied down to the last drop, through the drain hose and straight into the sink – up to a height of 50 cm.



A CLASS OF ITS OWN.

- Save space when transporting and storing: simply fold the handle forward and remove the squeegee tool.
- For flexible work in cramped areas, the handle can be put into the right position in one movement.
- The arch-shaped squeegee tool with its patented mounting system actively adjusts to the movements of the machine and thus picks up the dirty water without any residues, even in corners.



RA 43|B20

L x W x H	800 x 530 x 790 mm
Working width	430 mm
Suction width	730 mm
Theoretical coverage max.	1720 m ² /h
Noise level	63/59* dB(A)
Empty weight	56 kg
Operating weight (76 Ah 5)	134 kg

BATTERIES/ELECTRICAL DATA

Rated voltage	24 V
Power max.	950 W
Number of batteries	2
Capacity gel	76 Ah 5

TANK

Solution tank capacity	20 l
Recovery tank capacity	23 l

SUCTION

Low pressure max.	110 mbar
Air flow max.	32 l/s

BRUSHES AND PAD HOLDERS

Number	1
Speed	180 rpm
Brush pressure	30 kg

*silent version, optional.

- ❶ Fast, easy and hygienic: changing system of accessories. The brushes and pad holders can be automatically dropped on/off with a simple touch of a button.
- ❷ The standard version with its 10 A integrated charger and powerful batteries allows for up to 2.5 hours of continuous operation.
- ❸ Optional: the silent version with a noise level of just 59 dB(A).
- ❹ noBAC® version optional: antibacterial tanks for every kind of sites with stringent hygiene requirements according to HACCP concept or following hygiene plan.



PERFECT SUCTION. EXTREMELY ROBUST:
THE 40 LITRE CABLE MACHINE THAT GOES ON AND ON.

RA 43|K40

RA 55|K40



Practical: cleaning accessories always close at hand



Greater comfort with large wheels



Quick and easy seal changes



Perfect suction results even in tight turns



	RA 43 K40	RA 55 K40
L x W x H	1090 x 475 x 1055 mm	1130 x 525 x 1055 mm
Working width	430 mm	550 mm
Suction width	735 mm	735 mm
Theoretical coverage max.	1720 m ² /h	2200 m ² /h
Noise level	66 dB(A)	66 dB(A)
Empty weight	65 kg	66 kg
Operating weight	105 kg	106 kg

ELECTRICAL DATA

Rated voltage	230 V	230 V
Power max.	1600 W	1600 W
Mains cable	25 m	25 m

TANK

Solution tank capacity	40 l	40 l
Recovery tank capacity	45 l	45 l

SUCTION

Low pressure max.	204 mbar	204 mbar
Air flow max.	45 l/s	45 l/s

BRUSHES AND PAD HOLDERS

Number	1	1
Speed	150 U/min	150 U/min
Brush pressure	36 kg	37 kg

- The compact, mains operated scrubber dryer for continuous duty on small and medium size surfaces.
- Up close: the moulded, ergonomic operating handle and the single-axis design provide effortless manoeuvrability in the tightest space.
- Large wheels for greater comfort and easy transport.
- The mains operated machine is low in weight, making it the ideal solution for pressure sensitive floors.
- Large fresh water opening with mesh insert for rapid filling without the need to open the tank cover.
- Easy to clean: the recovery tank has smooth walls and opens fully for rinsing and disinfection. HACCP compliant.
- The cover seals can be changed quickly and easily without tools.
- Compact design and removable squeegee tool for easier handling and transport.
- Exceptionally high brush pressure for perfect cleaning results.
- Simple, intuitive operation with a self-explanatory display.
- The patented mounting system of the curved squeegee tool follows the movements of the machine and leaves no streaks even in tight turns.
- Available in working widths of 43 cm or 55 cm.
- EUnited tested and certified.
- Made in Germany.

THE BLUE ALL-ROUNDER. THE 40-LITRE CLASS.

RA 43|B 40
RA 55|B 40

🕒 The new manoeuvrable all in the 40 litre class deliver the convenience and equipment for long, intensive cleaning work combined with the benefits of easy handling and compact dimensions. Extremely easy to use and configurable for any requirement, they make the efficient cleaning of small and medium sized areas a real pleasure! The diversity of options and the typical columbus features make professional cleaning more effective - productivity which pays dividends.

Without any compromise:

- 🕒 Robust mechanics: reliable operation without downtimes using the mechanical brush unit and squeegee tool lowering system.
- 🕒 High brush pressure: best cleaning results, even on extremely dirty floors.
- 🕒 Superb suction: the powerful suction motor and the adjustable curved shaped squeegee tool ensure streak-free floors which can be walked on immediately.

- 🕒 Whisper noise level: silent equipment as standard for cleaning during business hours and in noise sensitive areas.
- 🕒 Fast adjustable guiding bar: for fatigueless and ergonomic work.
- 🕒 Intuitive display: clear and functional, easy to use for everybody.
- 🕒 Quick Stopp as standard: maximum safety and uncompromising convenience for the user.
- 🕒 As close as possible: developed to work right into the corners.



AS CONVENIENT AS A LARGE MACHINE.
AS COMPACT AND MANOEUVRABLE AS A SMALL ONE.

RA 43|BM 40 RA 55|BM 40

Extremely easy to service:

- ⦿ Fast and clean at the touch of a button: automatic tool change using the patented brush connection system.
- ⦿ Short set-up times: easy access to the chemical dosing system.
- ⦿ Hygiene made easy: the dual tank system (including tool free removable cover seal) ensures hygienic cleaning and disinfection according to HACCP standards.

⦿ Functional and tidy: run-off hose attached securely on the side.

⦿ Easy maintenance: recovery tank can be tilted laterally for quick access to batteries and motors.

⦿ Flexible operation: using the on-board charger, as standard equipment.

Consistent and environmentally friendly:

⦿ Not too much and not too little: the electronic water dosing system supplies precisely the correct volume of cleaning solution.

⦿ Protects the environment and your wallet: equipped with integrated chemical dosing system.

⦿ Even lower consumption: the special columbus water-stop brushes and the splash guard reduce water and chemical consumption to a minimum.

⦿ Particularly hygienic: the optional noBAC® version is recommended for all areas with high hygiene requirements.

⦿ And: Made in Germany.



TWO WORKING WIDTHS.



	RA 43IB 40	RA 55IB 40
L x W x H	1190 x 510 x 980 mm	1250 x 570 x 980 mm
Working width	430 mm	550 mm
Suction width	735 mm	850 mm
Theoretical coverage max.	1720 m ² /h	2200 m ² /h
Noise level	60 dB(A)	60 dB(A)
Empty weight	71,5 kg	73,5 kg
Operating weight	189 kg (105 Ah 5)	192 kg (105 Ah 5)

BATTERIES/ELECTRICAL DATA

Rated voltage	24 V	24 V
Power max.	950 W	950 W
Number of batteries	2	2
Capacity gel min.	76 Ah 5	76 Ah 5
Capacity gel max.	105 Ah 5	105 Ah 5

TANK

Solution tank capacity	40 l	40 l
Recovery tank capacity	45 l	45 l

SUCTION

Low pressure max.	110 mbar	110 mbar
Air flow max.	32 l/s	32 l/s

BRUSHES AND PAD HOLDERS

Number	1	1
Speed	180 rpm	180 rpm
Brush pressure	24 kg	23 kg

TWO VERSIONS.



RA 43|BM 40

RA 55|BM 40

L x W x H	1190 x 510 x 980 mm	1250 x 570 x 980 mm
Working width	430 mm	550 mm
Suction width	735 mm	850 mm
Theoretical coverage max.	1720 m ² /h	2200 m ² /h
Noise level	60 dB(A)	60 dB(A)
Empty weight	82 kg	84 kg
Operating weight	203 kg (105 Ah 5)	205 kg (105 Ah 5)

BATTERIES/ELECTRICAL DATA

Rated voltage	24 V	24 V
Power max.	1130 W	1130 W
Number of batteries	2	2
Capacity gel min.	76 Ah 5	76 Ah 5
Capacity gel max.	105 Ah 5	105 Ah 5

TANK

Solution tank capacity	40 l	40 l
Recovery tank capacity	45 l	45 l

SUCTION

Low pressure max.	110 mbar	110 mbar
Air flow max.	32 l/s	32 l/s

TRACTION

Power max.	150 W	150 W
Speed max.	4 km/h	4 km/h

BRUSHES AND PAD HOLDERS

Number	1	1
Speed	180 rpm	180 rpm
Brush pressure	21 kg	25 kg

THE GREAT LIGHTWEIGHT.
FOR PRESSURE-SENSITIVE FLOORS.

RA 66|KM 60



- ⦿ This scrubber dryer features high brush pressure, light weight, strong traction motor and extra-long mains cable for clean floors in gymnasiums and multi-purpose halls, that can be walked on immediately.
- ⦿ Standard large surface coverage: the mains cable is 25 m long; tanks constructed in a space saving manner contain 60 litres each.
- ⦿ The brush pressure can be adapted to the level of pollution of the floors and set to an optimum setting depending on the nature of the floors.
- ⦿ At a low weight of 240 kg max. both models are suitable and in particular made for use on pressure-sensitive surfaces according to DIN 18032-2.
- ⦿ Get started quickly, work for longer: mains operated, continuous working time without downtimes for recharging.
- ⦿ The recovery tank with sleek inner walls has a large opening for fast and thorough cleaning, the cover gasket can be removed and replaced according to the hygiene regulations HACCP.
- ⦿ Easy access to all components.
- ⦿ Work effortlessly and safe: the handle bar is shaped ergonomically, the control panel is self-explanatory.

RA 66|KM60

L x W x H	1400 x 680 x 1000 mm
Working width	660 mm
Suction width	980 mm
Theoretical coverage max.	2640 m ² /h
Noise level	70 dB(A)
Empty weight	180 kg
Operating weight	240 kg

ELECTRICAL DATA

Rated voltage	230 V
Power max.	1825 W
Mains cable	25 m

TANK

Solution tank capacity	60 l
Recovery tank capacity	60 l

SUCTION

Low pressure max.	230 mbar
Air flow max.	50 l/s

TRACTION

Power max.	200 W
Speed max.	5,5 km/h

BRUSHES AND PAD HOLDERS

Number	2
Speed	200 rpm
Brush pressure min./max.	33 / 36 kg

SWITCH IN A FLASH: THE PATENTED MOUNTING SYSTEM FOR BRUSHES AND PAD HOLDERS.

RA 55|BM 60
RA 66|BM 60

- Especially designed for varying needs, this scrubber dryer with traction motor masters every situation and guarantees thoroughly cleaned surfaces of medium and large sizes.
- Effortless and safe to use, even over longer working times: ergonomically shaped handle bar, easy to operate control panel including a rocker function for back- and forward movements, good all-around visibility.
- Compact design; with a length of 138 cm, it fits into all standard lifts.
- Optional: Various tyre variants for optimum adaption to diverse working conditions.

*Picture with optional equipment



🔴 Environmentally friendly: the optional chemical dosage provides for a consistently high cleaning level with a low consumption of cleaning products.

🔴 Excellent suction performance with minimal noise: the suction motor has noise emissions of just 61 dB(A); the optional silent version of just 58 dB(A).

🔴 noBAC® version optional: antibacterial tanks for every kind of sites with stringent hygiene requirements according to HACCP concept or following hygiene plan.

🔴 Extremely adaptable: the adaptive brush system sits flat on the floor also on uneven surfaces – and cleans every little centimeter with full brush pressure.

🔴 Fast, easy and hygienic: changing system of accessories. The brushes and pad holders can be automatically dropped on/off with a simple touch of a button.

🔴 DEKRA and EUnited tested and certified.

🔴 Made in Germany.



- Service-friendly: the recovery tank tilts to the side for easy access to batteries and components.



- Fresh water can be filled up in an instant – via the integrated, industry-standard system connector or via the large filling opening.



- The two-tank system guarantees hygienic cleaning and disinfection in accordance with the HACCP Concept.



- Mop, broom and additional work materials can be carried along within easy reach on the optional tool board located on the side.



	RA 55 BM60	RA 66 BM60
L x W x H	1470 x 550 x 1100 mm	1375 x 680 x 1100 mm
Working width	550 mm	660 mm
Suction width	850 mm	980 mm
Theoretical coverage max.	2200 m ² /h	2640 m ² /h
Noise level	61/58* dB(A)	61/58* dB(A)
Empty weight	140 kg	147 kg
Operating weight (160 Ah 5)	324 kg	331 kg

BATTERIES/ELECTRICAL DATA

Rated voltage	24 V	24 V
Power max.	1240 W	1240 W
Number of batteries	4	4
Capacity wet	175 Ah 5	175 Ah 5
Capacity gel	180 Ah 5	180 Ah 5

TANK

Solution tank capacity	60 l	60 l
Recovery tank capacity	60 l	60 l

SUCTION

Low pressure max.	110 mbar	110 mbar
Air flow max.	32 l/s	32 l/s

TRACTION

Power max.	300 W	300 W
Speed max.	6 km/h	6 km/h

BRUSHES AND PAD HOLDERS

Number	1	2
Speed	150 rpm	180 rpm
Brush pressure	30 kg	40 kg

*silent version, optional.

The patented mounting system

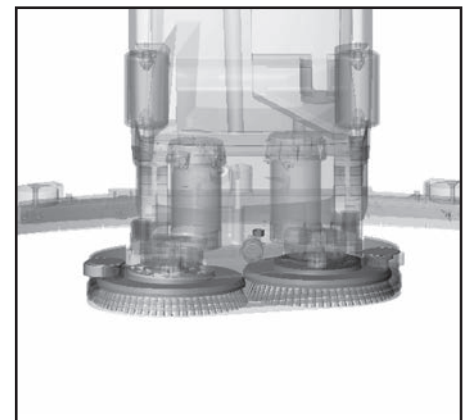
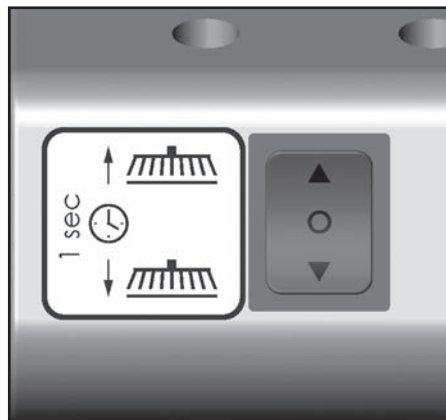
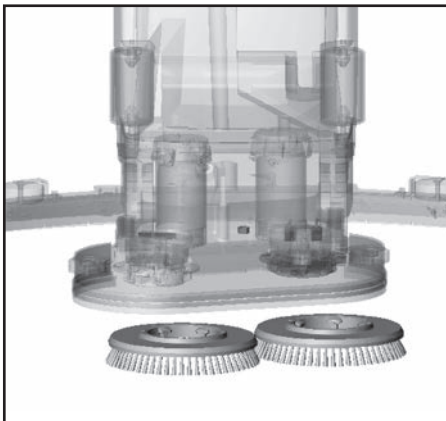

PREMIUM CLASS:
MAXIMUM EFFICIENCY FOR MEDIUM AND LARGE AREAS.

RA 85|BM 90



*Picture with optional equipment



- **The 90-litre class delivers the optimum in comfort and flexibility for professional cleaning in the toughest conditions. It elegantly combines great performance over large surfaces with simple operation and maximum manoeuvrability.**
An impressive overall concept with outstanding efficiency.
- **Quick-Fill system:** The machine is filled autonomously with 90 litres of fresh water via the Quick-fill connection with Auto-Stop.
- **Powerful performance:** Two 800-watt brush motors ensure uncompromising cleaning performance.
- **Optimum suction:** The adjustable curved suction nozzle and the powerful suction motor pick up the dirt even on bends without leaving any residue.
- **Fast adjustment:** Work ergonomically at any height with the quick to adjust steering handle.
- **Compact construction:** With a length of 138 cm, the machine fits in all common lifts and can be completely turned around within 1.6 m.
- **Long running time:** Up to 5 hours running time, thanks to a battery capacity of up to 285 Ah 5.
- **And: Made in Germany.**

PREMIUM CLASS. FOR INDUSTRY AND RETAIL.

User-friendly:

- ⦿ Fast and clean at the touch of a button: Automatic change of work tools with the patented brush holder system.
- ⦿ Short set-up times: Chemical dosing and chemical tank accessible from the outside.
- ⦿ Simply hygienic: The two-tank system and tool-free exchangeable lid seals ensure hygienic cleaning and disinfection in compliance with the HACCP concept or hygiene plan.
- ⦿ Simply clean: The long waste water hose is attached to the side to save space and allows convenient emptying.

Environmentally conscious:

- ⦿ Always right: With the standard electronic water dosing system, the amount of cleaning solution required is dosed, constantly ensuring optimum cleaning performance for the entire duration of use.
- ⦿ Good for the environment and your budget: The optional integrated chemical dosing system.

Suitable for industrial use:

- ⦿ Different tyre variants: Configurable to the requirements of the property to be cleaned.
- ⦿ Robust overall concept: Reliable performance without downtimes, thanks to the use of high-quality components.
- ⦿ Adjustable brush pressure: The adjustable brush pressure of up to 73 kg guarantees first-class results, even on the most heavily soiled floors.





RA 85|BM90

L x W x H	1380 x 890 x 1235 mm
Working width	850 mm
Suction width	980 mm
Theoretical coverage max.	3360m ² /h
Noise level	60 dB(A)
Empty weight	154 kg
Operating weight	436 kg (240 Ah 5)

BATTERIES / ELECTRICAL DATA

Rated voltage	24 V
Power max.	2340 W
Number of batteries	4
Capacity wet max.	255 Ah 5
Capacity gel max.	285 Ah 5

TANK

Solution tank capacity	90 l
Recovery tank capacity	95 l

SUCTION

Low pressure, max.	110 mbar
Air flow, max.	32 l/s

DRIVE MOTOR

Rated current	300 W
Speed	6 km/h

BRUSHES AND PAD HOLDERS

Number	2
Speed	180 U/min
Power brush motor	2 x 800 W
Brush pressure	43 - 73 kg



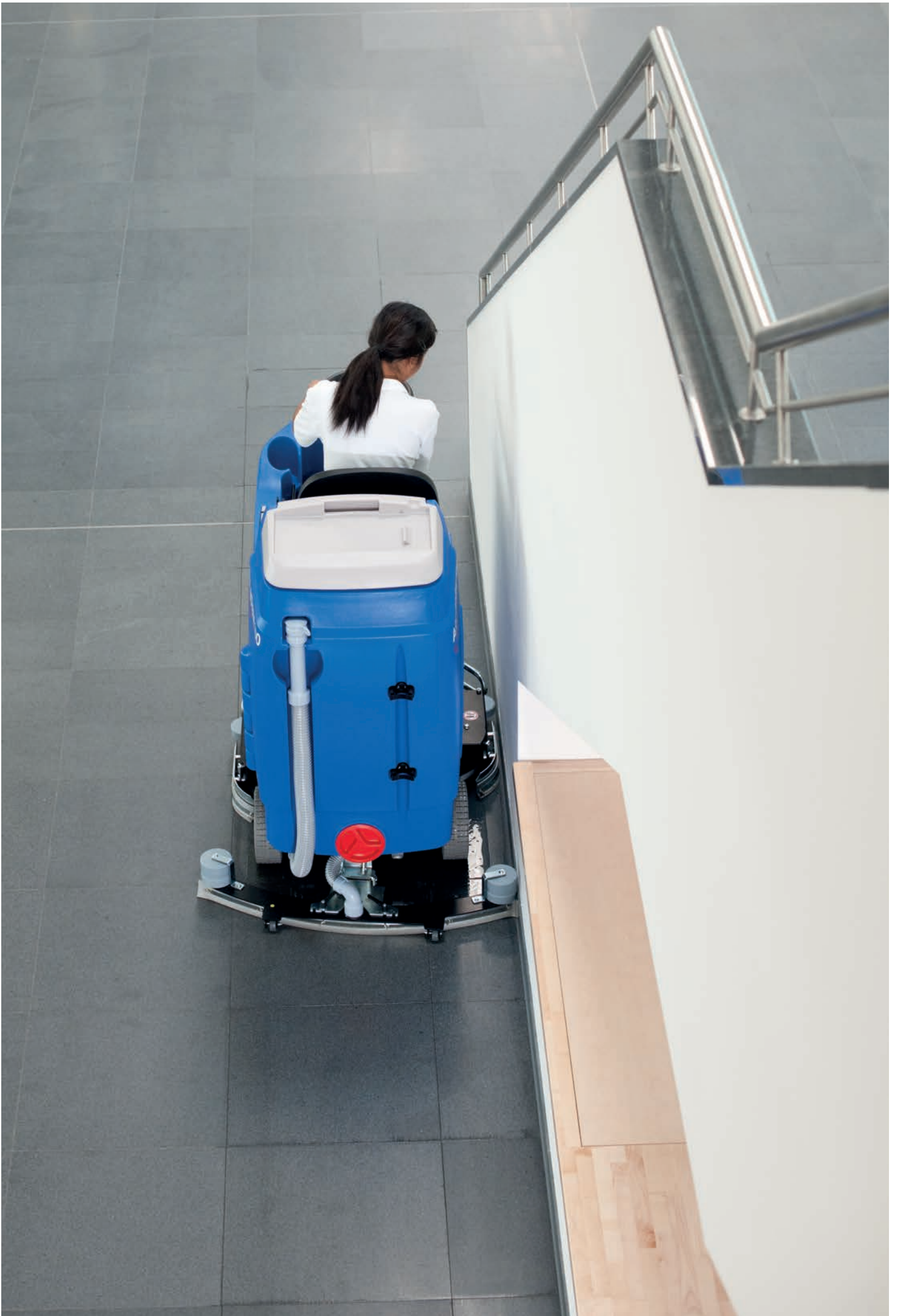

ERGONOMIC. EFFICIENT.
AND EXCEPTIONALLY COMPACT.

ARA 66|BM70

- ❶ With a capacity of 70 litres, this ride-on scrubber dryer from columbus can perform efficient operations, even – and especially – in hospitals, supermarkets and other small buildings even with cramped and heavily-furnished areas.
- ❷ The standard electronic water dosing system allows exact water supply following the needs of different cleaning tasks.
- ❸ Whether the operator is just 155 cm or 195 cm tall, the long seat allows everyone to find the right position to work fatigue-free and relaxed.
- ❹ Fast, easy and hygienic: changing system of accessories. The brushes and pad holders can be automatically dropped on/off with a simple touch of a button.



With small operator

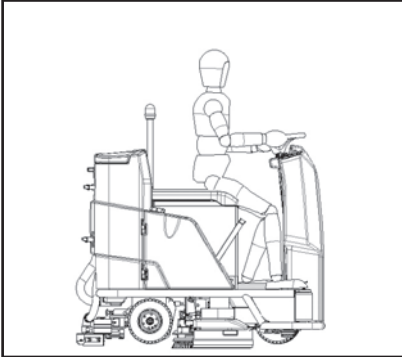

With tall operator

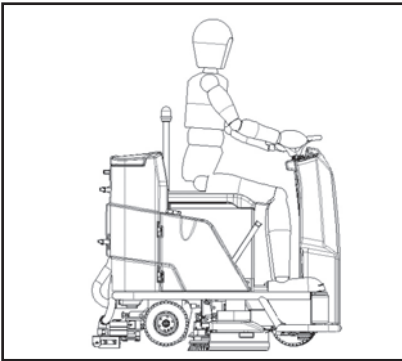

Pull-out filter for large debris



Emergency stop button



- Fresh water can be filled up in an instant – via the integrated, industry-standard system connector or via the large filling opening.
- HACCP hygiene standards: the solution and recovery tank have inspection openings and can be thoroughly cleaned, the lid seal can be removed without tools.
- Robust mechanics: simple operating switches to turn the machine on and off and for forward and backward movements. Mechanical lowering of brushes and squeegee.
- Powerful traction motor and rear-wheel drive allow scrubbing on inclines of up to 12%.
- Optional: Various tyre variants for optimum adaption to diverse working conditions.



MECHANICS INSTEAD, SMART ELECTRONICS AND LOTS OF USEFUL FEATURES.

- Easy service: the seat can be lifted up to provide free access to batteries and components.
- The arch-shaped squeegee tool with patented mounting system adapts actively to the movements of the machine and will perfectly pick up without leaving any waste water even on tight turns.
- Operators can act quickly and flexibly thanks to a low step height, an open cockpit on both sides and a spacious footwell.
- Just 138 cm long and 85 cm wide, the ride-on scrubber dryer fits into all standard lifts and can easily negotiate narrow check-out areas.



ARA 66|BM70

L x W x H	1380 x 680 x 1170 mm
Working width	660 mm
Suction width	850 mm
Theoretical coverage max.	3960 / 4620 m ² /h*
Noise level	63/59** dB(A)
Empty weight	187 kg
Operating weight (180 Ah 5)	456 kg

- Optional: silent-version that operates at only 59 dB(A) and a security-kit for advanced security when used in facilities that are open to the public.
- Environmentally friendly: the optional chemical dosage provides for a consistently high cleaning level with a low consumption of cleaning products. The 8 litres chemical tank can be removed without tools.
- A faster clean: the area covered every hour is up to 600 m² larger compared to the performance of walk-behind scrubber dryers of the same size.
- DEKRA tested and certified.
- Made in Germany.



BATTERIES/ELECTRICAL DATA

Rated voltage	24 V
Power max.	1690 W
Number of batteries	4
Capacity wet	200 Ah 5
Capacity gel	180 Ah 5

TANK

Solution tank capacity	70 l
Recovery tank capacity	80 l

SUCTION

Low pressure max.	110 mbar
Air flow max.	32 l/s

TRACTION

Power max.	750 W
Speed max.	6 / 7 km/h

BRUSHES AND PAD HOLDERS

Number	2
Speed	180 rpm
Brush pressure	30 kg

*available with 6 km/h or 7 km/h

**silent version, optional.

EXCEPTIONAL MANOEUVRABILITY. EFFICIENT.
RELIABLE. IN ONE WORD: FUNCTIONAL.

ARA 66|BM 100
ARA 80|BM 100



*Picture with optional equipment



- ❶ The easy to operate, compact ride-on scrubber dryer is ideal for the daily cleaning of – among others – clinics and hospitals, smaller to medium industrial buildings and markets with narrow alleys and checkout zones.
- ❷ Battery capacity up to 320 Ah 5 for longer working time of up to 8 hours.
- ❸ Rugged mechanics instead of electronics: simple operating switches to turn the machine on and off and for forward and backward movements. Mechanical lowering of brushes and squeegee.
- ❹ Service- and maintenance-friendly: the recovery tank can be swiveled to the side, making components and battery fully accessible.
- ❺ Easy to transport: with an overall length of just 138 cm both models fit into all common lifts.
- ❻ The rear-wheel drive provides for good traction, the extremely tight turning radius of 1.9 m enables the use in multiple applications, such as narrow corridors and hallways.
- ❼ Effortless and safe to use: ergonomic operator's seat with good all-around visibility.
- ❽ The optional chemical dosage provides for a consistently high cleaning level with a low consumption of cleaning products.
- ❾ Equipped for great functionality, customized and adapted to the cleaning task: the silent version works at a reduced noise level of only 60 dB (A) and features an integrated battery charger as well as a security-kit for advanced security when used in facilities that are open to the public.
- ❿ Optional: Various tyre variants for optimum adaption to diverse working conditions.
- ⓫ noBAC® version optional: antibacterial tanks for every kind of sites with stringent hygiene requirements according to HACCP concept or following hygiene plan.

GOOD IN THEORY.



GOOD IN PRACTICE.



	ARA 66 BM 100	ARA 80 BM 100
L x W x H	1380 x 730 x 1325 mm	1380 x 900 x 1325 mm
Working width	660 mm	800 mm
Suction width	850 mm	980 mm
Theoretical coverage max.	4620 m ² /h	5600 m ² /h
Noise level	64/60* dB(A)	64/60* dB(A)
Empty weight	258 kg	263 kg
Operating weight (320 Ah 5)	690 kg	695 kg

BATTERIES/ELECTRICAL DATA

Rated voltage	24 V	24 V
Power max.	2290 W	2290 W
Capacity wet	250 Ah 5**/320 Ah 5	250 Ah 5**/320 Ah 5
Capacity gel	240 Ah 5**/280 Ah 5	240 Ah 5**/280 Ah 5

TANK

Solution tank capacity	100 l	100 l
Recovery tank capacity	115 l	115 l

SUCTION

Low pressure max.	170 mbar	170 mbar
Air flow max.	33 l/s	33 l/s

TRACTION

Speed max.	7 km/h	7 km/h
------------	--------	--------

BRUSHES AND PAD HOLDERS

Number	2	2
Speed	160 rpm	160 rpm
Brush pressure	50 kg	50 kg

*silent version, optional.

**with integrated charger.

The easy-grip steering wheel



MORE LITRES. MORE WORKING WIDTH. MORE FLEXIBILITY. SIMPLY MORE EFFICIENCY PER TANK.

ARA 85|BM 120

- ❶ The ARA 85|BM 120 is a highly efficient ride-on scrubber dryer for larger areas. One full tank allows you to clean for two hours without stopping.
- ❷ The standard electronic water dosing system allows exact water supply following the needs of different cleaning tasks and enables the planning of efficient cleaning operations.
- ❸ Efficiency that starts even before the cleaning process: the fast-filling system switches off automatically as soon as the solution tank is full. Brushes and pad holders can be uncoupled and coupled again at the touch of a button.
- ❹ Ergonomic design: the long seat is more comfortable for the user, allowing to work more effectively.
- ❺ Quick and flexible operation: low access height, cockpit open on both sides and spacious foot area.
- ❻ Efficient cleaning with no waiting time: the curved squeegee tool and the powerful suction guarantee streak-free floors that can be walked on straight away.



- ◉ Flexible, quick and manoeuvrable: compact dimensions and a small turning circle of 1.95 m allow effective cleaning right up to the edges, even in tight spaces.
- ◉ Intelligent and sustainable: cleaning with an optional chemical dosing system that uses only the precise quantity of chemicals required. This leads to better cleaning results and less consumption of chemicals. It helps the environment!
- ◉ Safety and clear vision: optimal illumination of the working area thanks to LED front lights. Additional safety is ensured by optional warning lights. The tyre versions can be adjusted to specific location requirements and offer maximum comfort.
- ◉ Quick and easy: good access to both tanks through large service hatches for easy and in-depth cleaning. The lid seal can be removed without tools.



120 LITER.
MADE IN GERMANY.

ARA 85|BM 120

- Optimal machine utilisation: the silent version allows absolutely quiet cleaning even during business hours and in noise-sensitive areas.
- Very sustainable thanks to its long lifetime: a robust construction, high-quality components and perfectionist assembly ensure reliable operation and calculable follow-up costs.
- Easy made high value preservation: service markings and easy access to all parts simplifies day-to-day care of the machines.
- DEKRA tested and certified.
- Made in Germany.



Quickly filling up



Electronic water dosing system as standard



ARA 85|BM120

L x B x H	1490 x 880 x 1260 mm
Working width	850 mm
Suction width	980 mm
Theoretical coverage max.	5100 m ² /h
Noise level	62/60* dB(A)
Empty weight	209 kg
Operating weight (240 Ah 5)	596 kg

Removable chemical tank

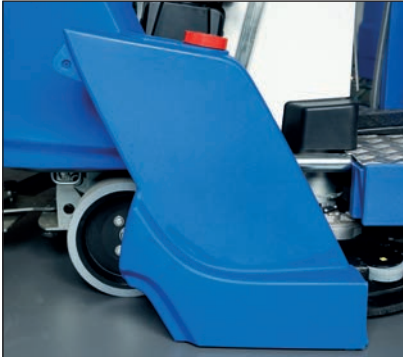

LED front lights as standard



BATTERIES/ELECTRICAL DATA

Rated voltage	24 V
Power max.t	2395 W
Number of batteries	4
Capacity wet	on request
Capacity gel	240 Ah 5

TANK

Solution tank capacity	120 l
Recovery tank capacity	140 l

SUCTION

Low pressure max.	110 mbar
Air flow max.	32 l/s

TRACTION

Power max.	750 W
Speed max.	6 km/h

BRUSHES AND PAD HOLDERS

Number	2
Speed	180 rpm
Brush pressure	40 kg

* silent-version, optional.



STRONG PERFORMANCE. READY TO GO
AT THE PUSH OF A BUTTON. SIMPLY CONVENIENT.

ARA 80|BM 150
ARA 100|BM 150



*Picture with optional equipment



- ❶ The large ride-on scrubber dryer for long working times and high surface coverage of up to 7.500 sqm.
- ❷ High battery capacity up to 480 Ah 5 for a working time of up to 10 hours.
- ❸ The completely steady, infinitely variable brush pressure provides for perfect adaptation to the most varied and textured surfaces.
- ❹ With a light touch of the automatic button, the squeegee tool is lowered and the brush head placed in stand-by position. A simple touch of the accelerator puts all functions in motion: the brushes are lowered into the desired working position, exact brush pressure is activated, the pump supplies the right amount of water – the scrubber works in a pre-set mode. Operating errors are all but eliminated, a consistently high cleaning result can basically be "preset"!
- ❺ The recovery tank with sleek inner walls is easily accessible and therefore easy to clean.
- ❻ For effortless work with less stoppage: great machine ergonomics, matured and proved engineering for comfortable and trouble-free working.
- ❼ Drain hose at the lowest point of the tank allows for dosed or complete drainage of the tank.
- ❽ Locking brake for safe stopping and parking.
- ❾ Optional: spray lance for best cleanliness even into the corners.

BEST CLEANLINESS EVEN INTO THE CORNERS.
WITH THE OPTIONAL SPRAY LANCE.



*Picture with optional equipment

ARA 80|BM150**ARA 100|BM150**

L x W x H	1880 x 930 x 1440 mm	1900 x 1100 x 1440 mm
Working width	800 mm	1000 mm
Suction width	1180 mm	1370 mm
Theoretical coverage max.	6000 m ² /h	7500 m ² /h
Noise level	64 dB(A)	64 dB(A)
Empty weight	330 kg	370 kg
Operating weight (280 Ah 5)	915 kg	955 kg

BATTERIES/ELECTRICAL DATA

Rated voltage	24 V	24 V
Power max.	2380 W	2380 W
Capacity wet	480 Ah 5	480 Ah 5
Capacity gel	280 Ah 5	280 Ah 5

TANK

Solution tank capacity	150 l	150 l
Recovery tank capacity	150 l	150 l

SUCTION

Low pressure max.	170 mbar	170 mbar
Air flow max.	33 l/s	33 l/s

TRACTION

Speed max.	7,5 km/h	7,5 km/h
------------	----------	----------

BRUSHES AND PAD HOLDERS

Number	2	2
Speed	160 rpm	160 rpm
Brush pressure max.	100 kg	100 kg



ORIGINAL COLUMBUS RANGE OF ACCESSORIES: BEST QUALITY FOR MORE RETURN OF INVESTMENT.

The accessory range of columbus offers the right cleaning concept for every application. The first-class brushes and pad holders made in Germany guarantee the best cleaning results and efficiency. With the patented quick and easy drop-off system, the brushes and pad holders can be dropped and picked up at the touch of a button.

Brushes

- ❶ High quality and long life span: columbus brushes feature a dense network of bristles – for advanced stability, smooth running cycles and low levels of wear and tear.
- ❷ Improved cleaning performance: hollow grind of the brush tips allows for flat positioning of the brushes on the surfaces also when under pressure, outer bristles sit at an angle to enable thorough cleaning up to the edge.
- ❸ The particular structure of the bristles enables an ideal water distribution over the entire surface.
- ❹ Less consumption of water with Water-Stopp brushes: special bristles enable up to 40% water savings. Thus, the high-quality columbus brushes make an important contribution to sustainable cleaning.
- ❺ These high quality five components brushes are made for a perfect cleaning of highly structured floors. The special bristles made of five components and the special arrangement of the bristles allow a thorough and deep cleaning of structured surfaces.

columbus scrub brushes



columbus pad holders

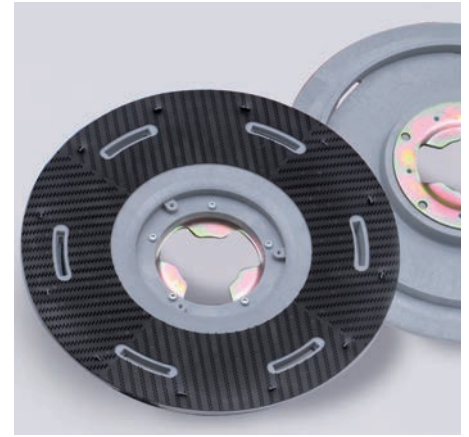

columbus brushes for the patented mounting system



columbus pad holders for the patented mounting system

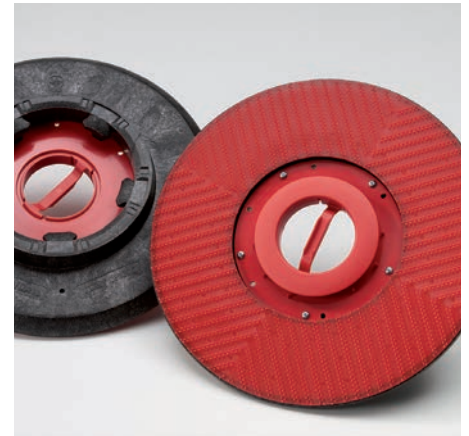

Five component brush



Pad holders

- ❶ Functional, reliable and durable: the red disc with small attachment hooks is made from hard-wearing polyamide, glued and additionally clamped together. Specially shaped hooks provide for better adhesion of pads.
- ❷ Lightweight, solid and durable: the base plate is made of foamed polypropylene and worked in a way so that the pads sit flat on the surface, ensuring much higher cleaning efficiency.
- ❸ Solid connectors made of steel and polypropylene (PP): perfect guide with less wear and tear.

Pads

- ❶ The high-quality pads feature a long life cycle and guarantee a consistently good cleaning result, even for the most demanding tasks. The application possibilities range from daily cleaning up to deep cleaning of heavily used floors. The quantity of detergents can be reduced significantly. Therefore the use of columbus pads is an important contribution to sustainable cleaning.



Squeegee blades

- ❶ The original columbus squeegee blades guarantee the best suction results for streak-free and immediately dry floors.



Batteries

- ❶ High-performance batteries from reputed manufacturers guarantee long operating intervals and the economical use of all scrubber dryers.



HYGIENE PLUS: SCRUBBER DRYERS WITH THE noBAC® SYSTEM.

ANTI BACTERIAL SOLUTION AND RECOVERY TANKS

columbus noBAC® systems have been specially developed for use in hospitals, homes for the elderly, kitchens and the food industry – in other words, every area that has stringent hygienic requirements (HACCP).

noBAC® tanks are made of polyethylene enriched with an anti-bacterial, inorganic additive.

They are optionally available for columbus scrubber dryers B20, B/BM 40, BM 60 and ARA 100.

How it works

- The additive works from the inside out, and prevents microbial growth in micro-fissures, dead-spots and rough surfaces. Bacteria are prevented from multiplying.
- The noBAC® combination of active substances (polyethylene and additive) has been tested in relation to the bacteria strains Escherichia coli, Staphylococcus aureus and methicillin-resistant Staphylococcus aureus (MRSA), as stipulated by ISO 22196.

Benefits

- Better hygiene and disinfection.
- Less work cleaning the machines, shorter service times for cleaning tanks, less expenditure on chemicals.
- noBAC® does not have a use-by date – it works for the entire life-span of a tank.
- The noBAC® combination of active substances is both food-safe and compatible with every chemical – there are no interactions.

Environmental protection

- The production, use and recycling of the tanks does not damage the environment at any point.
- Non-hazardous to health.

The diagram shows how noBAC® protection reduces bacteria growth over the course of three days.

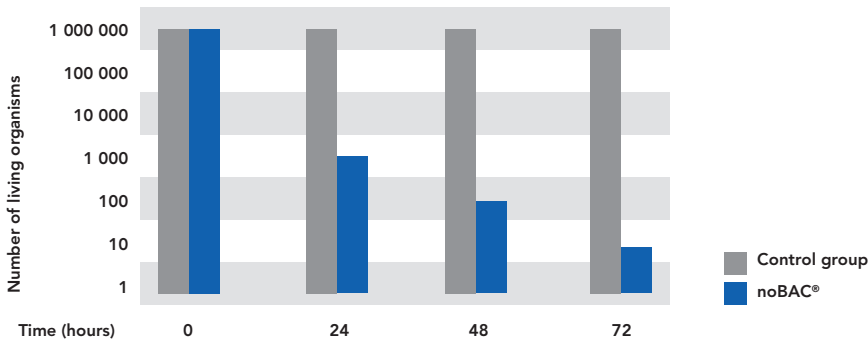

SUSTAINABILITY AT COLUMBUS: ONLY WHAT LASTS LONG IS REALLY SUSTAINABLE.

Less material consumption by puristic engineering, targeted use of recyclable materials, intelligent dosing systems, energy-efficient smooth running gearboxes. These are just a few of the parameters that we use to optimize the sustainability of our products. The most important task, however, is and will always be the quality and longevity of our machines.

Less material consumption thanks to economic design.

- Keeping things as compact as possible reduces material consumption and achieves the highest possible efficiency of the energy used. The tanks of Columbus scrubber dryers are one example: constructed using innovative double-wall technology, the solution tank encases the battery compartment, saving space and weight.

Less water consumption due to the intelligent dosing system.

- The standard integrated electronic water dosing system guarantees an exact dosage of fresh water. The machine only consumes as much water as it is necessary for a thorough cleaning. No more and no less.

Less impact on the environment due to lower consumption of detergents.

- The integrated dosage is regulated electronically, and the mixing ratio is always ideal: if less water is supplied, then fewer chemicals are used. Floors are thus cleaned gently and stay beautiful. In a sense, every cleaning cycle is an act of environmental protection.

Less energy consumption thanks to best quality transmissions.

- Smooth running gearboxes require less energy to achieve the necessary power output for the brushes and the traction motor for optimal results.

Our contribution to environmental protection by recycling.

- Most materials used for Columbus scrubber dryers can be recycled. The mainly used materials are steel and polyethylene. Polyethylene can be grinded into pellets and reused as a raw material for new tanks, and steel can be recycled such that it retains its original quality. The machines are equipped with electro-mechanical elements as far as possible. These mechanical components are easily recyclable and safe valuable raw materials.

This is the way we built machines: robust and long lasting. Following our strong conviction that only what lasts long is really sustainable.

