

travel 600

**Operating Manual
Escalator Cleaning Machine**



Read these instructions carefully before operating the machine!



Preface

To this operating and maintenance manual

This operating and maintenance manual (OMM) is an important part of the product travel 600 and is routinely delivered together with a travel 600.

It is a necessary precondition to read and understand this OMM in order to be able to work efficiently and safely with the travel 600.

The OMM contains important information on the handling, safety and maintenance and is therefore indispensable for all persons handling this machine.

Please read this OMM thoroughly in order to be able to handle the travel 600 in an optimal way and to obtain the ability to act correctly in preparing the use and the cleaning of the machine as well as in possible cases of faults – not at last for your own safety.

Signs and Symbols used in the OMM

For better understanding and quicker orientation we have used signs and symbols in some parts of the OMM.

The following symbols have been used:

Warning signs; signs that warn of risk or danger



Warning of danger

Indicates a potentially dangerous situation. In case of disregarded severe injuries could be the consequence.



Warning of dangerous electric voltage

Indicates a potentially dangerous situation when touching live parts. In case of disregarded severe injuries or death could be the consequence.



Warning of slipping

Indicates a potentially dangerous situation on wet or slippery grounds.

Signs giving order for an obligatory behaviour



Use eye protection

Wearing protective goggles



Use gloves

Wear protection gloves



Use of protective boots

Wearing of suitable protective shoes or boots

Signs of information: tips to facilitate the use of the machine



- Symbol for
- Further detailed explanations and information
 - Useful tips for the use of the machine



- Indicates special information (tips)
- For optimal employment or
 - For easier handling of the machine

The following signs are used in the OMM

- Here individual points are enumerated
- Here the consequence of an action are explained or described
- Here a main clause is broken down into a number of subordinate clauses
- [] here actions or procedures are explained in an illustration

Illustrations and listing of connecting numbers

In order to better illustrate the parts of the machine and ways of usage some illustrations have been added at some points in the OMM. Relevant parts on the machine are indicated with lines and connecting numbers and are listed next to or below the illustration. Objects or actions are marked with an arrow in the illustration or indicated with a character (e.g. [A]).

Table of contents

PREFACE	2
<hr/>	
61 BASIC SAFETY REGULATIONS	6
<hr/>	
1.1 PREFACE	6
1.2 DUTIES OF THE OPERATING AUTHORITY	6
1.3 USAGE ACCORDING TO PURPOSE	6
1.4 OPERATING PERSONNEL	6
1.5 FOR THE SAFETY OF THE USER	7
1.6 MODIFICATIONS AND CHANGES ON THE MACHINE	7
1.7 GENERAL SAFETY INSTRUCTIONS	7
1.8 SPECIAL SAFETY INSTRUCTIONS	7
1.9 SAFETY DEVICES	8
1.9.1 THE FIXING BRAKE OF THE GUIDING WHEEL	8
1.9.2 THE EMERGENCY SWITCH-OFF	8
1.10 SAFETY INSTRUCTIONS FOR MAINS OPERATED MACHINES	8
1.11 SPECIAL RISKS AT THE MACHINE – SOURCE OF DANGER	9
1.12 SIGNS AND STICKERS	9
1.13 HOW TO REACT IN CASE OF EMERGENCY	9
2 GENERAL DESCRIPTION	10
<hr/>	
2.1 BASIC PROBLEM	10
2.2 CONSTRUCTIVE FEATURES – PRINCIPLE OF THE TRAVEL 600	10
3 TECHNICAL DATA	11
<hr/>	
3.1 TECHNICAL FIGURES	11
4 HANDLING / USAGE	12
<hr/>	
4.1 TRANSPORT OF THE TRAVEL 600 TO PLACE OF WORK	12
4.2 BEFORE STARTING TO WORK	12
4.3 PREPARATIONS/SAFETY MEASURES AT PLACE OF WORK	12
4.3.1 MOVING DIRECTION OF TRAVELATOR/ESCALATOR	12
4.4 PREPARING THE MACHINE FOR WORK	13
4.4.1 CHECKING THE BRUSHES, VACCUMING CYLINDERS	13
4.4.2 FILLING IN OF CLEANING SOLUTION	13
4.4.3 THE OPERATING PANEL	14
4.5 CONNECTION SCHEME	15
4.6 CLEANING THE TRAVELATOR/ESCALATOR WITH THE TRAVEL 600	15
4.6.1 SIDEWAYS MOVEMENT OF THE TRAVEL 600	16
4.6.2 FINISH THE CLEANING PROCEDURE	16
4.6.3 DISPOSAL OF WASTE WATER	16
5 TROUBLESHOOTING	17
<hr/>	
5.1 THE MACHINE DOES NOT START	17

5.2	AREA CLEANED IS TOO WET	17
5.3	THE TREATED AREA IS NOT CLEAN OR ONLY IRREGULARLY CLEAN	17
6	<u>CHECKING, CLEANING AND CHANGING OF PARTS</u>	<u>19</u>
6.1	BRUSHES	19
6.2	VACUUMING CYLINDER (SUCTION ROLE)	19
6.3	UNDERPRESSURE SENSOR	20
6.4	PRESSURE SENSOR	20
6.5	SPRAY NOZZLE	20
6.6	DIRTY WATER TANK	21
7	<u>SERVICE AND MAINTENANCE</u>	<u>22</u>
7.1	CLEANING EQUIPMENT AND ITS USE	22
7.2	SERVICE AND INSPECTION LIST	22
8	<u>CLEANING SOLUTIONS</u>	<u>23</u>
9	<u>DECLARATION OF CONFORMITY</u>	<u>24</u>
10	<u>APPENDIX</u>	<u>25</u>
10.1	LIST OF ABBREVIATIONS	25
10.2	SPACE FOR YOUR NOTES	26

1 BASIC SAFETY REGULATIONS

1.1 Preface

The travelator/escalator cleaner travel 600 is built according to the latest technical standard and corresponding valid regulations.

Nevertheless some inevitable risks could remain for persons and objects. Therefore it is important that every person handling this machine should thoroughly read, understand and act according to this OMM and the safety information.

1.2 Duties of the Operating Authority

According to EU-Directive 89/655/EEC Art. 6 and 7 as well as EU-Directive 89/391/EEC Art. 1(1) and Art. 6(1) concerning the minimum safety and health requirements for the use of working equipment by workers at work, the operating authority is required to instruct these persons that are going to assemble, work with, maintain, repair or disassemble this machine.

Furthermore, according to Directive 89/655/EEC Art. 4a the operating authority is required to test the machine before usage, as well as after repairs and faults.

The following regulations are among the duties of the operating authority and are therefore taken for granted:

- Acting according to the above mentioned EU-Directive 89/655 and its national requirements.
- Acting according to the valid legal regulations on protection at work (e.g. laws on the protection at work, on safety at work, dangerous materials, lifts, etc.) according to regulations of the employer's liability association and rules for the prevention of accidents.
- Observing technical specifications
- Usage of the machine according to purpose

1.3 Usage according to Purpose

The safe operation of this machine is guaranteed only if it is used according to its purpose. The travelator/escalator cleaner travel 600 is designated for the exclusive use as a cleaning device for the inside and outside basic cleaning of travelator/escalator's. The travel 600 has to be handled by a person responsible for the whole process of cleaning.

Any further or other usage is seen as not according to purpose. The manufacturer is not liable for dangers resulting from this. The risk resulting from this lies in the sole responsibility of the operating authority or the user respectively.

Adequate usage according to purpose also includes the observance of the manufacturer's regulations on working, servicing and maintenance. Furthermore safety hints, signs and symbols are strictly to be followed and to be kept in a completely readable state.

The following points have to be considered:

- travel 600 is not suitable to vacuum dusts which may cause damage to health
- the machine is not explosion-proof
- the machine may be cleaned with a cleaner approved by the manufacturer only.
- travel 600 is not suitable for the cleaning of public streets.

1.4 Operating Personnel

Handling and maintenance as well as inspection and assembly may be executed by specially authorized and trained personnel only.

Trained personnel are trained service men of the operating authority, of the manufacturer and the service partners.

Persons working with the travel 600 necessarily have to :

- Be trained on the machine
- Be ordered explicitly to use travel 600
- Be at least 18 years of age
- Read and understood the operating and maintenance manual
- Consider the safety notices mentioned in the OMM
- Know the safety devices on the machine
- Know the moving pavement which is to be cleaned
- Know the position of the EMERGENCY SWITCH-OFF of the travelator/escalator
- Know the relevant regulations (e.g. for the prevention of accidents)

1.5 For the safety of the User

The relevant regulations on the prevention of accidents as well as generally accepted rules on safety, industrial medicine and traffic laws have to be followed.

Furthermore, the following point must strictly be observed:

- The electric plug may never be touched with wet hands.
- To unplug the machine grasp the plug, never the cable (current supply).
- Repairs may only be conducted by trained (electrician-) personnel
- The cleaner has to be handled with extra care. The rules and regulations (e.g. on stickers) by the relevant supplier are to be followed correctly.
- While working with the machine as well as during the preparatory work or after work duties it is required to wear suitable workwear.
- The personal protective gear for work with the travel 600 include the wearing of protective goggles, safety shoes and protective gloves.



If work on the open machine under electric tension is inevitable this may only be done by a trained electrician, who has knowledge of the dangers involved, respectively of the relevant rules (extensive norms DIN VDE 0100). For works under tension only specially approved tools may be used.

1.6 Modifications and Changes on the Machine

For safety reasons it is not allowed to make any changes on the machine. Changes without any authorization exclude the manufacturer's liability for damage of any kind resulting from this interference.

Original parts, spare parts and equipment are especially constructed for this machine and serve for your own safety. Parts and equipment of other manufacturers are not tested by us and therefore are not endorsed. Assembly, backfitting, maintenance and service require special knowledge and should be made by authorized personnel only.

1.7 General Safety Instructions

- If not in use this machine has to be locked into a safe place and the key (3) has to be removed from key switch (4) to prevent unauthorized usage. If locking in is not possible similar measures have to be taken.
- The mechanical as well as the electrical safety devices must not be changed or taken out of service.
- When working with the machine third parties have to be considered and any danger avoided.

1.8 Special Safety Instructions

- The local regulations for the prevention of accidents and for safety have to be followed. Orders, instructions and signs have to be observed.

- In the section of the landing the machine has to be held by the fixing brake of the the guiding wheel.
- Spilled cleaning liquid should be removed immediately in an appropriate way.
- Watch both the travelator/escalator and the machine closely – in case of sudden changes stop using the travel 600 immediately and contact authorized personnel.
- Switch off the machine with the key of the key switch if the machine stays unattended. Take precautions against unauthorized use.

1.9 Safety Devices

Check all safety devices daily or before starting to use the travel 600. Among the safety devices are:

1.9.1 The fixing brake of the guiding wheel

Check the fixing brake of the guiding wheel (10) for wear and tear and faultless functioning. In the case of too much wear and tear or not sufficient functioning the machine may not be further operated. The fixing brake prevents the travel 600 from rolling.

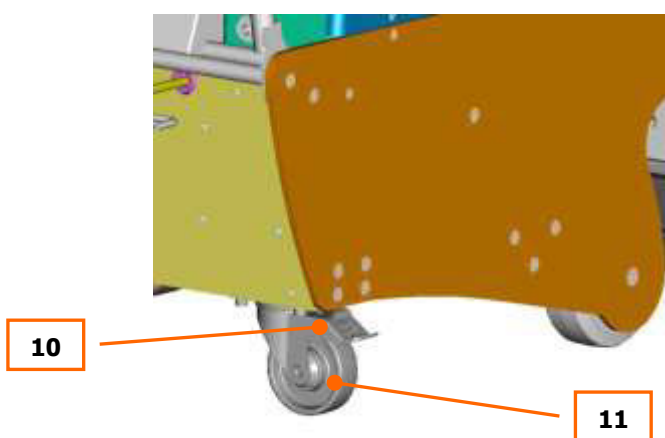

- (10) Fixing brake
(11) Guiding wheel

1.9.2 The EMERGENCY SWITCH-OFF

Check the EMERGENCY SWITH-OFF function daily before beginning to work and after every action on the machine.

The following procedure has to be followed:

- Connect to electric power with cable of travel 600
- Put key of key switch into position 1
- Press button Start (1) green lamp on
- Press EMERGENCY SWITH-OFF, the green lamp goes out
- After successful function test the EMERGENCY SWITH-OFF can be unlocked again

1.10 Safety Instructions for Mains operated Machines

It is important that the cable is not damaged by squeezing, tearing, friction or running over with the machine. The cable has to be checked regularly for damages, i.e. sections where the cable is blank, kinked or scorched. If the cable is not free from damage (e.g. damage of the protective covering) the machine must not be used. Before cleaning or service on the machine or when accessories are replaced the cable has always to be unplugged!

When changing parts such as brushes, vacuuming cylinders, sprayers, cable, plug etc. the regulations given by the manufacturer have to be observed and original spare parts used. Otherwise the safety of the machine could be affected. Damages on the main cable may be replaced by a repair center named by the manufacturer.

1.11 Special Risks at the Machine – Source of Danger



Danger by electricity:

To prevent the risk of electric shock works on the electrical parts of the machine must be executed by trained specialists. After finishing these works the safety measures have to be tested.



Danger while working with the machine:

Cables between the machine and supplies (electricity, water) are to be set in a way that the cable is not squeezed, is not coming into the way of action and does not create a stumbling-block.



The machine must never be left unattended on the landing of an travelator/escalator or on the travelator/escalator itself. If the machine gets out of control there is the risk of severe injury.



Danger after switching off the machine:

Works on the electrical parts of the machine must be executed by trained and authorized specialist.

1.12 Signs and Stickers

Signs and stickers on the travelator/escalator, on the machine and on the accessories have to be followed.

All signs and stickers on the machine have to be kept clean.

1.13 How to react in case of emergency

- Stop travelator/escalator at once and bring machine to a standstill by press button (1) or use EMERGENCY SWITCH-OFF (5) on operating panel (9).
- Disconnect cable (24) from supply.
- Pull machine away from travelator/escalator
- Thoroughly test machine and travelator/escalator (eventually consult specialists)
- Remove source of danger
- Eventually go back to work after complete fault clearance.

2 GENERAL DESCRIPTION

2.1 Basic Problem

Travelator/escalators transport a huge number of persons and things within various buildings and outside areas from one place to another.

Travelator/escalator are considerable dust collectors: crowds of people with wet, dirty, sandy and sticky shoes stay on the travelator/escalator for a few seconds and then go on. What is left are travelator/escalator whose grooves are littered with little stones, spilled fruit juice, pieces of broken glass, textiles and earth. Travelator/escalator become shoe cleaners.

Any kind of dirt becomes more noticeable if the surroundings are inviting and cleaned daily.

Travelator/escalator however are hardly ever cleaned – among other things because of the lack of cleaning machines. So even nowadays moving pavements are being hand-cleaned in a time and money-consuming way.

Our newly designed travel 600 is the answer to all these problems and returns travelator/escalators to their old brilliant form.

2.2 Constructive Features – Principle of the travel 600

The travel 600 is a newly designed cleaner which is handled and safely operated by one person.

The compact travel 600 cleans travelator/escalators quickly, thoroughly and close to the rim of travelator/escalators in movement. The special brushes rotating in opposite directions in connection with the patented vacuuming unit guarantee optimal cleaning results.

With the travel 600 travelator/escalators can be cleaned in a dry and in a wet way (by adding cleansing agents). The integrated powerful vacuuming prevents the dripping of cleansing agent into the travelator/escalators shaft (electrical and mechanical parts) and so guarantees a safe and careful cleaning free of residues.

With the help of a brake unit the machine is fixed on the travelator/escalator by the user. The dirt loosened from the travelator/escalator is vacuumed with the help of brushes, vacuuming cylinders and a wet pick-up vacuum cleaner and then collected in the waste water tank.

3 TECHNICAL DATA

3.1 Technical figures

The travel 600 consists of the brushing unit and the vacuuming unit and shows the following data:

Brush-Sucking Unit

Technical Specifications

Working Width	2 x 220 mm
Brush	4
Suction Roll	2
Mains Supply	~1 / 230 V /50 Hz
Electric Power Vacuum Motor	1500 Watt
Vacuum Capacity	162 m ³ /Min
Cleaning Agent Capacity	15 Liter
Soiled Water Tank	15 Liter
Vacuum	300 mbar
Noise Level	78 ± 2 dB (A)
Dimensions (L x B x H)	1195 x 536 x 930 mm
Weight (empty)	126 kg

4 HANDLING / USAGE

4.1 Transport of the travel 600 to place of work

Transport the travel 600 in an appropriate vehicle to its place of work. Fix the travel 600 in the trunk of your vehicle and prevent slipping of the machine. The machine may not be laid sideways. Arrest under all circumstances the fixing brake of the guiding wheel (10).

Take the travel 600 on its wheels to the area to be cleaned.

4.2 Before starting to work

Before every use the relevant safety regulations have to be considered and observed.

The travelator/escalator to be cleaned has to be inspected together with its operator. If necessary the operator has to be informed about existing changes of colour, repairs, spots of varnish, (irreparable) damages etc. on the travelator/escalator .

Before the first use of the travel 600 carefully study the use of the machine. Careful reading, understanding and acting according to the instructions are important preconditions for all works with the travel 600.

4.3 Preparations/Safety measures at place of work

The date of cleaning has to be determined with the personnel in charge (commissioning, caretaker, waste water disposal, company electrician etc.) If necessary the safety officer has to be informed.



The travelator/escalator has to be switched off by an authorized person and must be secured against unauthorized switching on. Take off the key of travelator/escalator!

The entrances at the upper and lower end of the travelator/escalator as well as the working area are to be closed off extensively against unauthorized persons by using sufficient safety devices (such as red and white barriers).

Leave these barriers in place until:

- The machine has been removed from the area of the travelator/escalator
- The travelator/escalator and the surroundings have dried up completely.

The necessary supply lines for the machine (e.g. electricity, water) have to be shown to the user by the personnel in charge. Furthermore the user has to make sure that a person competent to operate the travelator/escalator can be reached at any time nearby.

Find out where the EMERGENCY SWITCH-OFF for the travelator/escalator is situated.

Before cleaning check the intact profile of the travelator/escalator. If necessary remove objects from the grooves of the profile with the help of the accessories which are delivered together with the travel 600



Danger of severe injuries in wet and slippery surfaces



Please wear appropriate protective shoes at all times

4.3.1 Moving direction of travelator/escalator

While being cleaned the travelator/escalator must always move to the machine and the user.

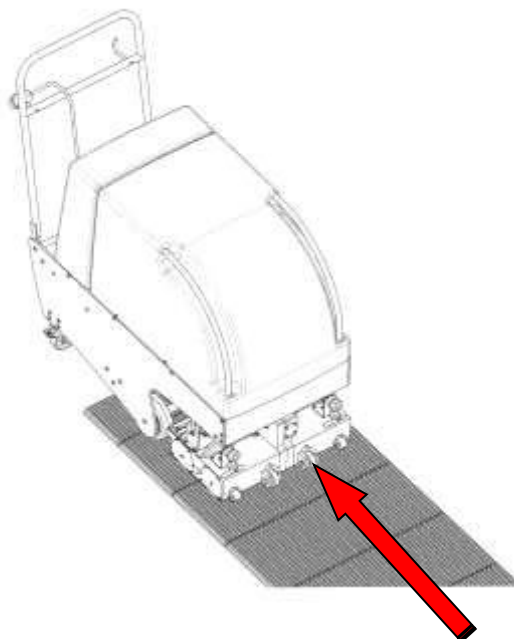

When cleaning ascending travelator/escalators the travel 600 must be operated only on the lower end.

Please always arrange with the operator of the travelator/escalator any necessary changes of the operating direction or the operating speed. While cleaning the travelator/escalator no changes of the motion control are possible.



The best cleaning results are obtained at a speed of 0,7 m/s.

4.4 Preparing the machine for work



The preparation has to be done exclusively:

- outside of the moving pavement area and
- The machine being switched off and fixed with the fixing brake of the guiding wheel (10).

Disconnect the travel 600 (24) and prevent unauthorized plugging in.

4.4.1 Checking the brushes, vaccuming cylinders

Before each use of the machine control the brushes and the vacuuming cylinders for dirt. Clean or change these parts if necessary.

4.4.2 Filling in of cleaning solution



Wear appropriate protective gloves when handling the cleaning solution

Take the brand and the ratio of the cleaning solution according to the information of the manufacturer. Observe all requirements set by the manufacturer of the solution.

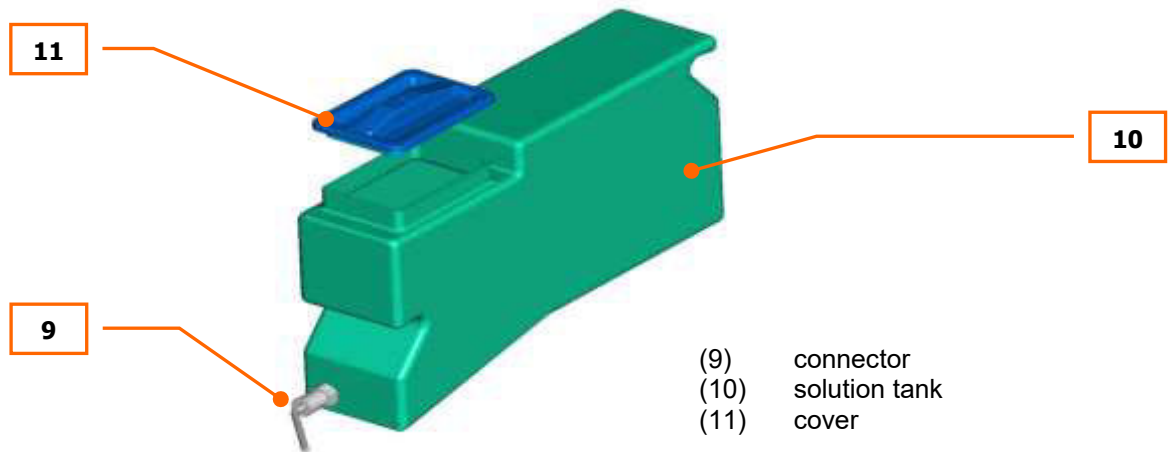

Procedure:

- loosen coupling (9) of the solution tank (10)
- fill in a maximum of 15 liters of prepared cleaning solution (mixture) to the solution tank
- put solution tank on travel 600 and close coupling.

4.4.3 The operating panel

The control of the cleaning procedure of the travel 600 is executed by the operating panel (9):

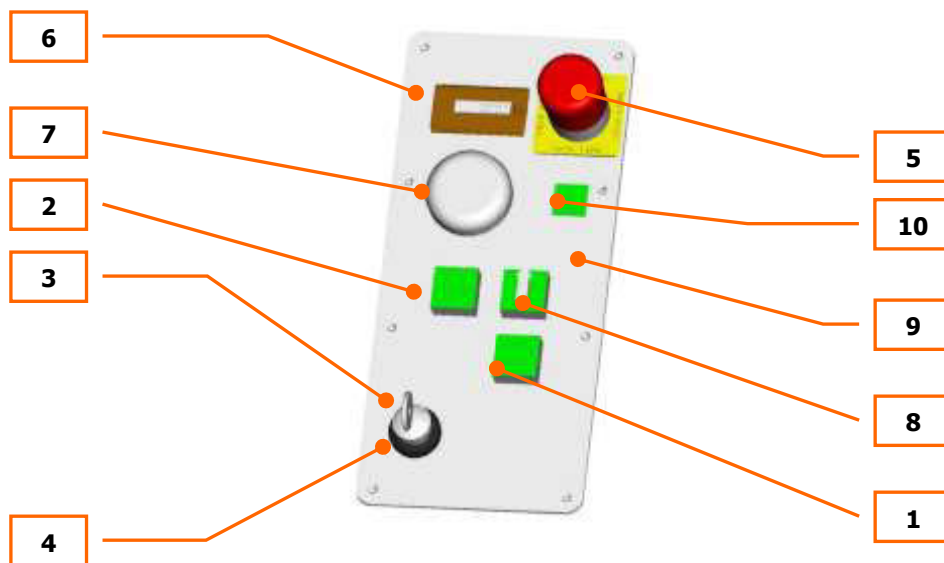

- | | |
|--------------------------|---------------------------------------|
| (1) On-Taster | (6) Hour meter |
| (2) Button Pump (on/off) | (7) Water sirene / signal pump |
| (3) Key | (8) Three step switch |
| (4) Key switch | (9) Operating panel |
| (5) EMERGENCY SWITCH-OFF | (10) Safety switch sucking-roll motor |

The operating panel consists of the ON-switch (1), the pump switch (2). Furthermore the key (3), the key switch (4), the working hour meter (6) and the EMERGENCY SWITCH-OFF (5) are placed on the operating panel. Switch for Waterflow (8) according to requirements about the pollution 1-3 (less-middel-much)

The following indications could show during the use of the travel 600:

Switch (1) lights green

The operating panel has been activated and the machine is now ready for use. This is the case if the key (3) of the key switch (4) has been put to position 1 and the ON- switch (1) has been pressed.

Switch (2) light green

The machine is working and the pump has been activated. The content of the solution tank is being sprayed on to the travelator/escalator by the pump and the spray nozzles.

Control light (7) for the supply of cleaning solution blinks

The solution tank is empty and has to be refilled. After refilling press switch (2). The control light (7) is no longer blinking. Then press switch (2) once more in order to activate the pump and spray the cleaning solution on to the travelator/escalator.

The working hour meter (6) shows the hours the machine has worked. It is only activated if the brushes of the travel 600 are rotating, i.e. if the machine is in the lowered position.

The EMERGENCY SWITCH-OFF (5) is an important safety device of the travel 600 and has to be pressed immediately in cases of emergency. The machine stops immediately.

4.5 Connection scheme

Observe under all circumstances the safety instructions for mains operated machines and connect the travel 600 as follows:

Complete connection of the travel 600:

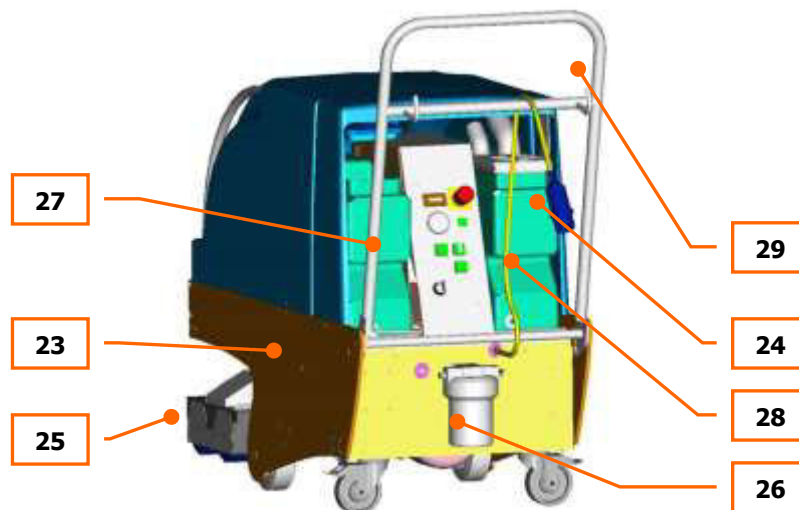

(23)	Frame travel 600	(27)	Solution tank
(24)	Power supply	(28)	Waste-water tank
(25)	Brush unit	(29)	Guiding bar
(26)	Water filter		

It is important to take care that no cables come into the area to be cleaned. Put all supply cables from the travel 600 backwards.

4.6 Cleaning the travelator/escalator with the travel 600

The machine cleans the travelator/escalator which has always to move to the user of the machine.

For operating the machine one person is necessary who stays at the machine during the whole process of cleaning. The person's hands hold the guiding bar all the time.

Immediately use the EMERGENCY SWITCH-OFF of the travelator/escalator and the EMERGENCY SWITCH-OFF (5) of the travel 600.

In the following a normal cleaning process of a travelator/escalator with the travel 600 is described.

Starting the travel 600

- push machine into the travelator/escalator
- push the foot brake with the foot and fix it.
- turn key (3) of key switch (4) to position 1
- switch on the machine by pressing ON switch (1) → switch (1) lights up
- switch on the spray pump by pressing the switch 2.

4.6.1 Sideways movement of the travel 600

Without any problems the travel 600 can be moved sideways with the machine switched on and the travelator/escalator moving.

- after the first track shows the desired cleaning results put the machine onto the next track.
- For this press switch (1), the brush-unit lift up.
- Move the machine out of the escalator/travelator. Position the machine on track 2 with two grooves of the already cleaned track 1 and track 2 overlapping. Under normal circumstances the machine has to be reset two times in order to clean the complete travelator/escalator (from track 1 to track 2 and from track 2 to track 3).



Avoid or stop immediately the leaking of solution on the travelator/escalator. Damage of the electrical or mechanical parts of the travelator/escalator could occur.

4.6.2 Finish the cleaning procedure

After the complete travelator/escalator shows the desired cleaning results the procedure can be finished.

- pressing switch (1) on operating panel (9).
- Move the machine out of the escalator/travelator.

Allow sufficient drying up time after the cleaning procedure.



Wet and slippery surface bear the risk of severe injuries.
Open the travelator/escalator for use only if the whole area is completely dried.

4.6.3 Disposal of waste water

For technical reasons there is cleaning solution and waste oil from the lubrication of the travelator/escalator in the waste water.

Therefore it is important to observe the regulations on the disposal of substances with environmental impact. Such substances are for example waste oil, cleaning solution, synthetic material or electrical parts. Please get informed about the relevant disposal.

5 TROUBLESHOOTING

Please check before each search for faults whether:

- The machine has been properly connected.
- The travel 600 is or was in the correct operating status (were all necessary components switched on according)
- the machine was in the correct operating position.



While searching for faults and clearance the machine has always to be disconnected. The key (3) of the key switch (4) must be set to position 0 and the cable has to be disconnected from the mains.

In the following there is a list of possible faults which may occur during the operation of the travel 600. According to the relevant symptom the possible reasons and measures for clearance are listed.

5.1 The machine does not start

Cause	Corrective
Machine has not be connected properly	Check all connections and connect properly.
EMERGENCY SWITCH-OFF (5) is pressed	Check position of EMERGENCY-SWITCH-OFF and possibly pull it out.
key (3) of key switch (4) is not set in position 1 and/ or switch (1) is not pressed	Turn key of key switch to position 1 and press switch (1)
Fault in the electricity of the house, safety fuses were blown.	authorized personnel can help
Switch (10) is cut out	Clean the sucking roles and press switch (10)

If the machine still does not start inform the after sales service office.

5.2 Area cleaned is too wet

Cause	Corrective
brushes are very dirty	Clean or replace brushes
Vacuuming cylinder is very dirty or choked	Clean or replace vacuuming cylinder
Vacuuming hose of wet pick-up cleaner is soiled	Clean vacuuming hose and connection

Further possible reasons:

Either too much cleaning solution or a cleaning solution with a too high percentage of soap has been used. Use only the cleaning solutions recommended by the manufacturer and observe the information on the dose. In any case after the cleaning procedure the escalator/travelator should be cleaned with normal water once more. Hereby all smears and solution leftovers are removed and the escalator/travelator is optically well presented.

5.3 The treated area is not clean or only irregularly clean

Cause	Corrective
The time measured for one cleaning turn is too short and/or the grooves were cleaned irregularly.	Clean the travelator/escalator once more resp. clean all grooves for an equal amount of time.
Spray nozzles are choked.	Check spray nozzles and clean if necessary.
Persistent dirt on the travelator/escalator	Repeat cleaning or use attachments to locally clean by hand.
Vacuuming cylinders are soiled or choked	Check vacuuming cylinder and clean or replace if necessary.
Wrong cleaning solution or ratio of mixture	Use correct cleaning solution and/or ratio of mixture.

	Use cleaning solution recommended by the manufacturer only and observe information on dose.
Brushes are very dirty/choked	Clean brushes or replace if necessary.
Spraying is not optimal	Check spray nozzles and filters

6 CHECKING, CLEANING AND CHANGING OF PARTS

For all checking, cleaning and changing of parts of the travel 600 the cable must be disconnected. These works must not be carried out near the escalator/travelator.



Wear protective gloves at all times to prevent the risk of injuries (e.g. cutting at sharp edges).

6.1 Brushes

How to change dirty or faulty brushes (41):

- Loosen all screws (42) of the side covering (43)
- Take off the side covering.
- Take out the brushes
- Change the brushes
- If necessary grease screws
- Put back the side covering

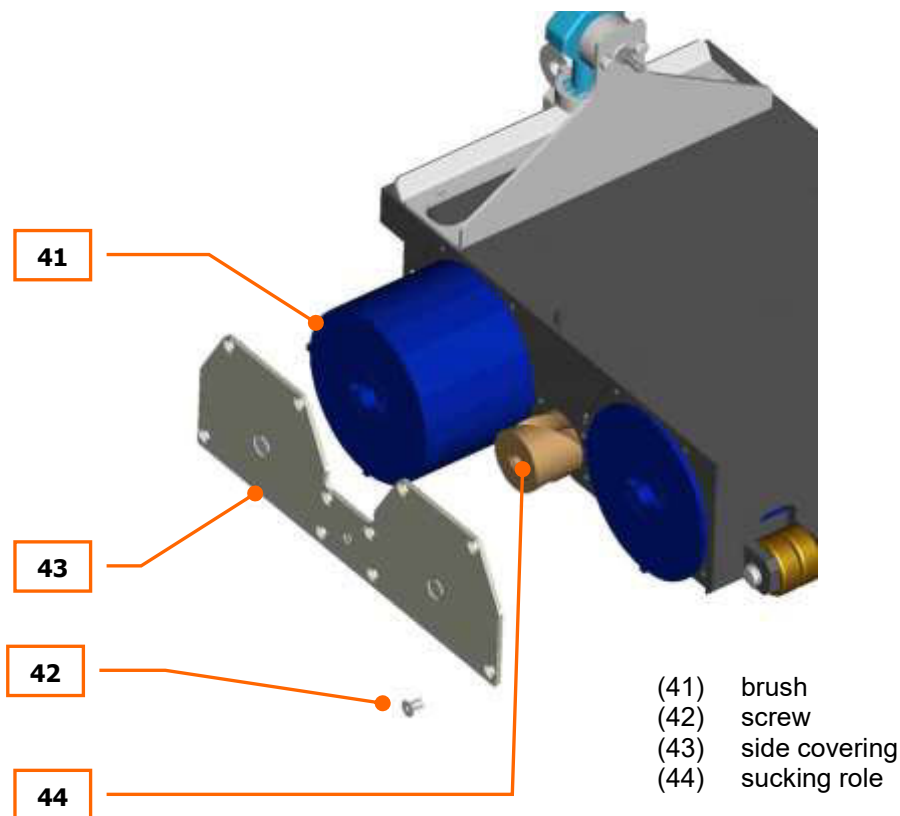

6.2 Vacuating cylinder (sucking role)

How to change a dirty or faulty vacuating cylinder (44):

- Loosen screws (42) of side covering (43)
- Take off the side covering
- Take out the vacuating cylinder
- Change vacuating cylinder (Pay attention to side of the vacuating cylinder it is stamped on the side of the cylinder. Just insert a left for a left and a right for a right cylinder!)
- If necessary grease screws
- Put back the side covering



In order to obtain optimal cleaning results the space where the brushes (41) and the vacuating cylinder (44) are situated should be checked for soiling (tilting the machine side-

ways). In case of soiling clean the space at the bottom of the travel 600 with a piece of cloth after taking out the brushes and the vacuuming cylinder.

After changing the brushes and/or the change of the vacuuming cylinder the side covering has to be fixed with the intended screws.

6.3 Underpressure sensor

The travel 600 checks the underpressure while cleaning. This is useful for a good suction from the Teavelator or escalator profile.

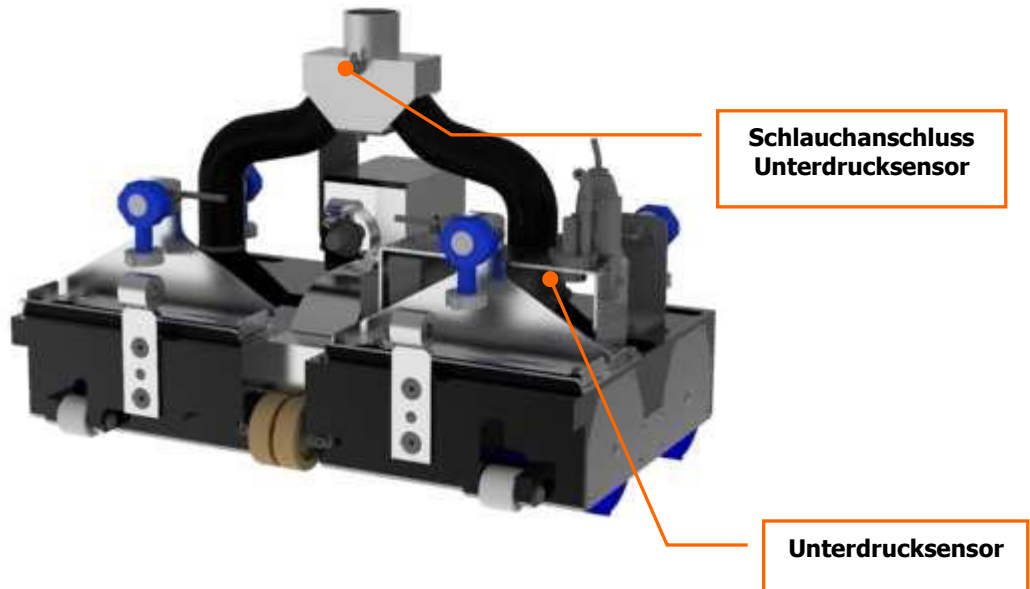

6.4 Pressure sensor

The travel 600 checks the pressure of the Spray pump. This sensor makes a noise if the fresh water tank is empty [piep – piep – piep – piep] long interval, the signal button blinks with the same frequency.



6.5 Spray nozzle

In order to check the functioning of the spray nozzles (57) have a look into the spray sector of the spray nozzles and press button(2).

If the spraying should not work properly it might be necessary to change the spray nozzle. Proceede as follows:

- Loosen the cap nuts (58) of the adapter (63)
- take out the complete spray nozzle (57)

Feinfilter Düsen vorgeschaltet:

Das Sprühbild sollte in etwa so aussehen:

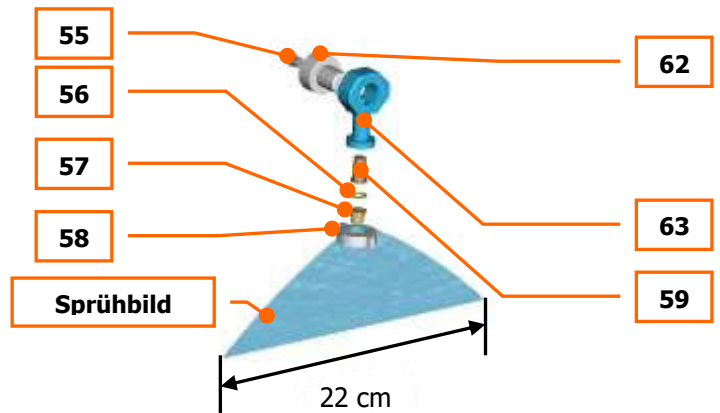
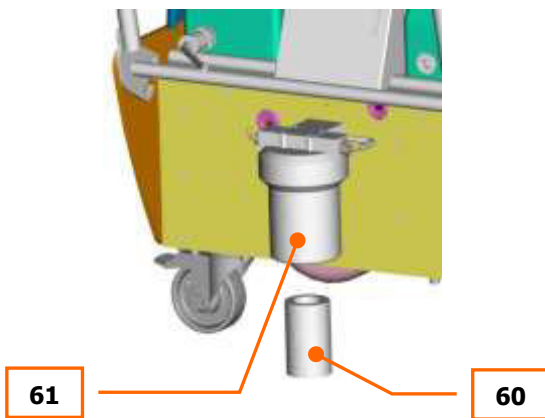

(55) Threaded crommet	(60) Finefilter 5 µm
(56) Flat gasket	(61) Housing filter
(57) Nozzle	(62) Pipe section Bajonett
(58) Cap nuts	(63) Adapter Nozzle-Filter
(59) Fine filter with return valve	

Check fine filter:

- Take of the housing filter (61)
- Take out the filter (60)
- Reconnect the assembly with a new filter or a purge filter
- Stud torque hand screwed

6.6 Dirty water tank

The dirty water tank collects the solution coming form the escalator or travelator. After pulling out the whole dirty water tank cover (incl. the swimmer) you can empty the dirty water tank. If the dirty water tank is full the swimmer closes and the underpressure sensor makes a viewable and hearable signal [piep.piep – piep.piep – piep.piep].The signal button blinks with the same frequency. You have to empty the tank. Than you can work on.

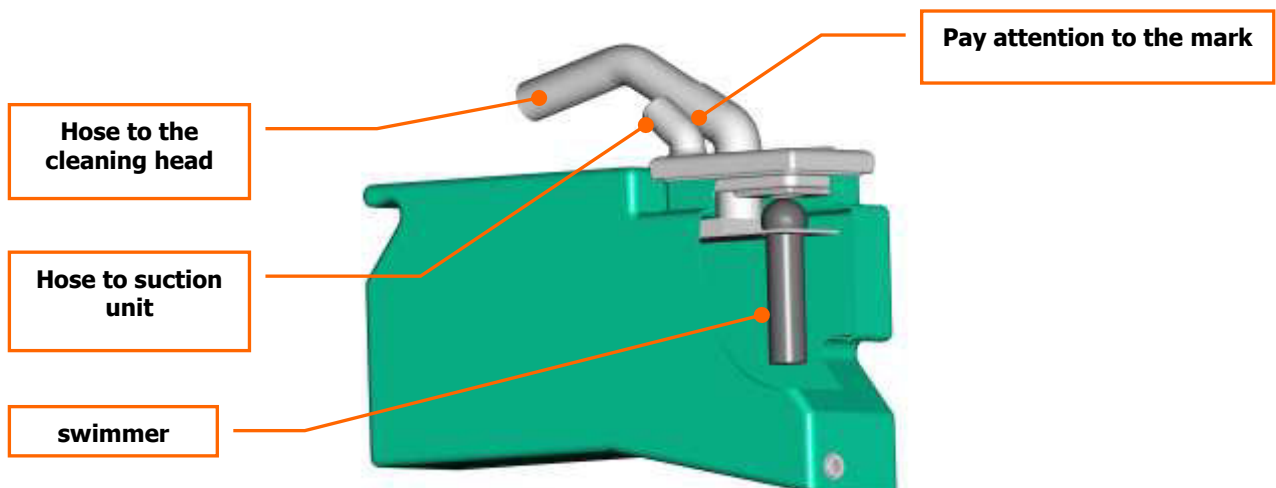

7 SERVICE AND MAINTENANCE

In order to get good cleaning results and to secure the longevity of the travel 600 it is necessary to regularly clean and maintain the machine.

If a soiled machine is used it is possible that the travelator/escalators are not properly cleaned or even get more dirty during the cleaning procedure.



Cleaning and maintenance only with the machine switched off and disconnected from the mains.

The personal protective gear has to be worn also for cleaning and maintaining the machine: This includes the wearing of protective glasses, shoes and gloves.



7.1 Cleaning equipment and its use

Clean all parts of the travel 600 with a slightly wet piece of cloth.



Do not clean with air pressure or high pressure cleaner!
Danger of severe (eye) injuries!

7.2 Service and Inspection List

Time interval	What to check	Procedure
Daily before beginning of work	Function of EMERGENCY SWITCH-OFF	Check before beginning of work
Daily before beginning of work	Fixing brake of guiding wheel (10)	Check before beginning of work (visual control) change if necessary
Daily before beginning of work	Vacuuming cylinders, spray nozzles, hoses and connections for dirt and wear and tear	Visual control. Change if necessary
Daily before beginning of work	Cables and connections for damage or interruption	Contact after sales service
Daily before beginning of work	Wheels for wear and tear	Visual control. Change if necessary or contact service
After 100 working hours	Complete machine: - bolts and screws	Check and/or contact after sales service
After every 100 working hours	Complete machine: - bolts and screws - drive line (Elbe)	Check and/or contact after sales service

8 CLEANING SOLUTIONS

- Cleaning solution (**Roto Esacal**)

Please use only the cleaning solution recommended by the manufacturer and observe the attached stickers, the information sheets and the rules on handling and dosage.

9 DECLARATION OF CONFORMITY

in accordance with the EC Directive on Machines 2006/42/EC



G. Staehle GmbH u. Co. KG
columbus Reinigungsmaschinen
Mercedesstraße 15
D-70372 Stuttgart

hereby declares that the following product conforms to the regulations of the above mentioned directive – as well as any modifications valid at the time the declaration was made.

Product: **Escalator Cleaning Machine**

Types: **travel 600**

The following related standards apply:

EN 60335-1:2007-02	Safety of electrical appliances for household and similar use - Part 1: General requirements
EN 60335-2-72	Safety of electrical appliances for household and similar use - Part 2-72: Special requirements for automatic machines for treating floors in commercial and industrial premises
EN 12100-1:2003	Machine safety - Basis terms, general design principles - Part 1: Basic terminology, methodology
EN 12100-2:2003	Machine safety - Basis terms, general design principles - Part 2: Technical principles and specifications
DIN EN ISO 13857:2008	Machine safety – Safety distance against reaching danger areas with the upper extremities
IEC 61000-6-2:01	Electromagnetic compatibility - Generic standard: Emitted interference - Part 2: Industry
IEC 61000-6-4:01	Electromagnetic compatibility (EMC) - Generic standard: Interference resistance- Part 2: Industrial applications

The following further EU Directive apply:

EMC Directive 2004/108/EG → 19.04.2016 / 20.04.2016 → 2014/30/EU

Stuttgart, 10.07.2019 Dipl. Ing.(BA) Erich Stockmann, Head of Design and Development

Authorized Documentation Representativ: Dr. M. Baumgärtel

10 APPENDIX

10.1 List of abbreviations

°C	degrees Celsius
Art.	Article
W	Width
OMM	Operating and Maintenance Manual
Resp.	respectively
Ca.	circa
cm	centimeter
dB	decibel
DIN Norm)	Deutsche Industrie Norm (German Industrial
EN	European Norm
etc.	et cetera
EU	European Union
EEC	European Economic Community
H	Height
Hz	Hertz
kg	Kilogramm
L	Length
mbar	Milli-Bar
Min.	Minute
mm	millimeter
V	Volt
VDE	Verein Deutscher Elektrotechniker (Association of German Electricians)

10.2 Space for your notes

G. Staehle GmbH u. Co. KG
columbus Reinigungsmaschinen
Mercedesstr.15
D - 70372 STUTTGART
Telefon +49(0)711 / 9544-950

info@columbus-clean.com
www.columbus-clean.com

columbus